

Design, Development & Implementation of Energy Saving System for Street Lighting Using Zigbee Network

Saleem P. Choudhary¹, Dr. Balaji G. Hogade², Dr. Ravish R. Singh³
*Department of Electronics and Telecommunication¹,
Department of Electronics²,
Department of Electronics and Telecommunication³,
M.Tech Student¹, Professor², Professor³
salemsggs@gmail.com¹, bghogade@gmail.com², ravishrsingh@yahoo.com³*

Abstract-The proposed street lighting system is highly energy efficient and automated. It uses ZigBee-based wireless devices which enable more streetlamp-system management. ZigBee network is connected to GSM system through computer which is located in base station. Sensor combination is used to control and guarantee the desired system parameters. The information is transferred to a control terminal using ZigBee network which is used to check the status of the street light. Appropriate action is taken whenever system fails. This system introduced to save electricity uses for street lights. It is compatible with the existing as well as modern LED based street lamps. However this system uses technology as ZigBee, GSM and few sensors in combination with PIC microcontroller.

Index Terms — control terminal; street lighting system; ZigBee network; ZigBee; energy saving; street light

1. INTRODUCTION

Lighting systems, especially in the public sector, are still designed according to the old standards of reliability and they often do not take advantage of the latest technological developments. In many cases, this is related to the plant administrators who have not completed the return of the expenses derived from the construction of existing facilities yet. However, the recent increasing pressure related to the raw material costs and the greater social sensitivity to environmental issues are leading manufacturers to develop new techniques and technologies which allow significant cost savings and a greater respect for the environment. We can find three possible solutions to these problems in the literature.

The first one, and perhaps the most intuitive, is the use of new technologies for the sources of light. In this area, light-emitting diode (LED) technology is the best solution because it offers many benefits. Researchers have already considered this possibility, designing an advanced street lighting system based on LEDs.

The second possible solution, and perhaps the most revolutionary, is the use of a remote-control system based on intelligent lamp posts that send information to a central control system, thus simplifying management and maintenance issues. Researchers have developed a street lamp system using the general-packet radio service (GPRS), power-line carrier, or Global Systems for Mobile Communications (GSM) transmissions.

Finally, the third possibility would be the use of renewable energy sources locally available, rather than conventional power sources, with a positive effect on the

environment. Solar energy is the most important resource in this field. Our work aims at the unification of the three mentioned possibilities, creating an intelligent lamp post managed by a re-mote-controlled system which uses LED-based light sources and is powered by renewable energy (solar panel and battery).

The control is implemented through a network of sensors to collect the relevant information related to the management and maintenance of the system, transferring the information via wireless using the ZigBee protocol. The field of the ZigBee re-mote sensing and control system is widely present in the literature; we can also find ZigBee systems similar to (the) lighting systems in structure and management.

In this project, we present our system, which is able to integrate the latest technologies, in order to describe an advanced and intelligent management and control system of the street lighting.

2. METHODOLOGY

The first one, and perhaps the most intuitive, is the use of new technologies for the sources of light. In this area, light-emitting diode (LED) technology is the best solution because it offers many benefits. Researchers have already considered this possibility, designing an advanced street lighting system based on LEDs.

The second possible solution, and perhaps the most revolutionary, is the use of a remote-control system based on intelligent lamp posts that send information to a central control system, thus simplifying management and

maintenance issues. Researchers have developed a street lamp system using the general-packet radio service (GPRS), power-line carrier, or Global Systems for Mobile Communications (GSM) transmissions.

Finally, the third possibility would be the use of renewable energy sources locally available, rather than conventional power sources, with a positive effect on the environment. Solar energy is the most important resource in this field. Our work aims at the unification of the three mentioned possibilities, creating an intelligent lamp post managed by a remote-controlled system which uses LED-based light sources and is powered by renewable energy (solar panel and battery).

The control is implemented through a network of sensors to collect the relevant information related to the management and maintenance of the system, transferring the information via wireless using the ZigBee protocol. The field of the ZigBee remote sensing and control system is widely present in the literature; we can also find ZigBee systems similar to the lighting systems in structure and management

In this project, we present our system, which is able to integrate the latest technologies, in order to describe an advanced and intelligent management and control system of the street lighting.



Figure 1: Architecture Image of the proposed model

3. PRIOR APPROACH

Automatic Street Lighting System uses NE555 Integrated Circuit and LDR, This project is all about to eliminate the manpower and reduce the energy consumptions at the street lights. This project includes controlling a circuit of street lights with the help of Transformer, Rectifier, Filter unit, LDR, NE 555 IC, BC 547 transistor, SPDT Relay, LED Lamp, resistance and capacitor during day and night. [4]

Automatic Street Lights This requires three basic components i.e. LDR, Sensors and microcontroller. During daytime there is no requirement of street lights so the LDR keeps the street light off until the light level is low or the

frequency of light is low the resistance of the LDR is high. This prevents current from flowing to the base of the transistors. Thus the street lights do not glow. As soon as the light level goes high or if light falling on the device is of high enough frequency, photons absorbed by the semiconductor give bound electrons enough energy to jump into the conduction band. The resulting free electron (and its hole partner) conduct electricity, thereby lowering resistance. Now the circuitry goes in on condition and the block diagram represented here starts working. [1]

Design and Implementation of Automatic Street Light Control Using Sensors and Solar Panel, new method is suggested so as to maximize the efficiency of the street lighting system and to conserve the energy usage the LED lights sensors. Here automation of street lights is done by LDR sensor. Intensity of led street lights can be controlled by IR sensor and pulse width modulation. [2]

Design and Implementation of an Automatic Street Light Control System, during the day the LDR senses enough illumination and the security light goes OFF. And when darkness comes resistance of the LDR increases tremendously and causes the light to come "ON". Also, a transistor switching a 12V Relay is deployed to provide the switching mechanism to activate the street lights connected in parallel. The need for manual operation of the security lights is completely eliminated and much energy is saved that would have been otherwise wasted if the user were to forget to power "OFF" the light at any point in time. This work was successfully designed, implemented and commissioned for use. [3]

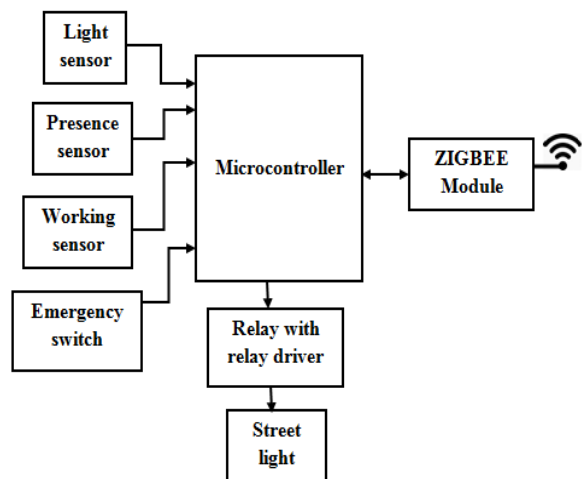

Figure 2: Node1

4. OUR APPROACH

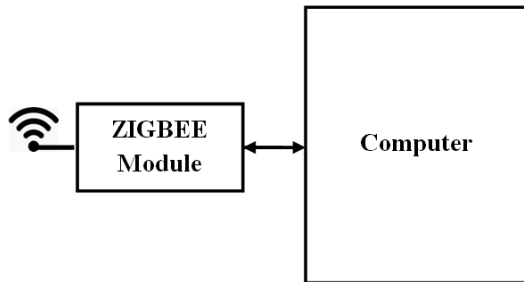

Figure 3: Monitoring station

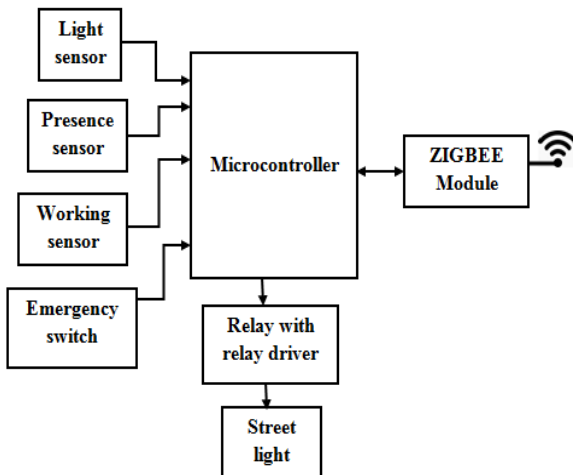

Figure 4: Node2

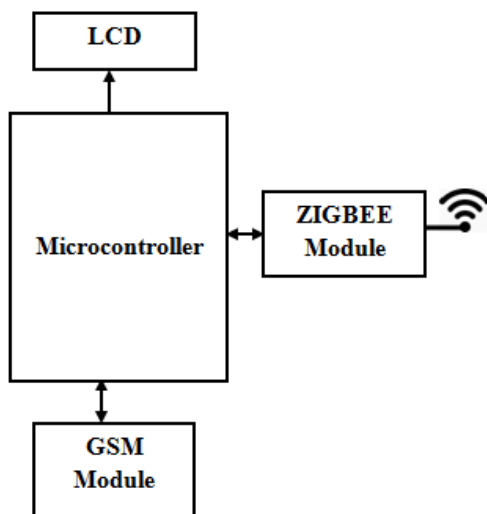

Figure 5: GSM control station

Figures show the block diagram of the proposed system. Each measuring system placed on the lamp monitors the street conditions like light intensity, presence of human being depending on these parameters they decide to turn the lights “ON” or “OFF”. The system also checks weather the lamp is working or not and sends the information through a wireless network. If any malfunction is detected, the service engineer is informed through a graphical interface and can perform corrective actions.

Here a GSM modem is connected to the computer in control room. In case light sensor fails to turn off light during the day time you can send a sms to turn off the light. The GSM modem is connected to PC the sms will be sent to the PC and the PC will send a command from the wireless n/w to turn off the particular lamp.

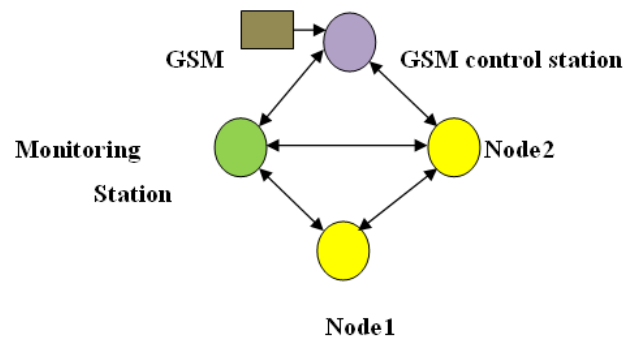

Figure 6: working of proposed model

Monitoring Stations

The monitoring station located in each lamp post consists of several modules: the presence sensor, the light sensor, the failure sensor, and an emergency switch. These devices work together and transfer all of the information to a microcontroller which processes the data and automatically sets the appropriate course of action. A priority in the transmission of information is as-signed to each sensor, for example, the emergency switch takes precedence over any other device.

Presence Sensor

The task of the presence sensor is to identify the passage of a vehicle or pedestrian, giving an input to turn on a lamp or a group of lamps. This function depends on the pattern of the street; in case of a street without cross-roads, a single sensor is sufficient (or one at each end in case of a two-way street), while for a street requiring more precise control, a solution with multiple presence detectors is necessary.

This feature enables switching on the lamps only when necessary, avoiding a waste of energy. The main

challenge with such a sensor is its correct placement. The sensor should be placed at an optimal height, not too low (i.e., to avoid any erroneous detection of small animals) nor too high (for example, to avoid failure to detect children). A study of the sensor placement enables deciding the optimal height according to the user needs and considering the specific environment in which the system will work.

Light Sensor

A light sensor can measure the brightness of the sunlight and provides information. The purpose of this measurement is to ensure a minimum level of illumination of the street, as required by regulations.

The sensor must have high sensitivity in the visible spectrum, providing a photocurrent high enough for low light luminance levels. For this reason, the phototransistor TEPT5700 (by Vishay Semiconductors) has been selected.

Based on the measured luminance, the microcontroller drives the lamp in order to maintain a constant level of illumination. This action is obviously not required during daylight time, but it is desirable in the early morning and at dusk, when it is not necessary to operate the lamp at full power but simply as a “support” to the sunlight. This mode enables saving electric power supplied to the lamp because the lamp is regulated by the combined action of the sensor and the microcontroller to ensure the minimum illumination required.

Operating Control

This sensor is useful to improve fault management and system maintenance. Thanks to this sensor (in this case, a Hall sensor), it is possible to recognize when the lamp is switched on. The system is able to recognize false positives, because identified parameters are compared with the stored data (e.g., lamps are switched off during daylight and the sensor in-correctly detects a fault, but the microcontroller does not report the malfunction because of additional logic functions). The information is reported through the ZigBee network to the station control unit, where the operator is informed about the location of the broken-down lamp and can send a technician to replace it. The system current is 1.5 A, so a sensor suited to detect this current is necessary. An appropriate threshold value to detect the operation of the lamp has been set between 1 and 1.5 A. The chosen sensor is the ACS756 of the Allegro Microsystems, an economical and precise solution for AC or DC current sensing, particularly suitable for communication systems. Thanks to this sensor, it is possible to store in the microcontroller’s memory the current value which flows in the LED lamp in normal operating conditions, enabling the online power consumption measurement.

Emergency Device

The system has an emergency button, which can be useful in case of an emergency. This device excludes the entire sensor system with the objective to immediately turn on the lamp. The light will remain on for a preset time. After that, the button must be pressed again. This prevents the system from being accidentally active even when the necessity ends. Obviously, this device does not work during the day, when there is no need for artificial light.

GSM Control Unit

The SMS sent from a person or operator will turn ON or OFF the street light if the system having any problem with Zigbee network. It will direct the node-1, node-2, and monitoring station to change the status of street lamp.

Output of the proposed model

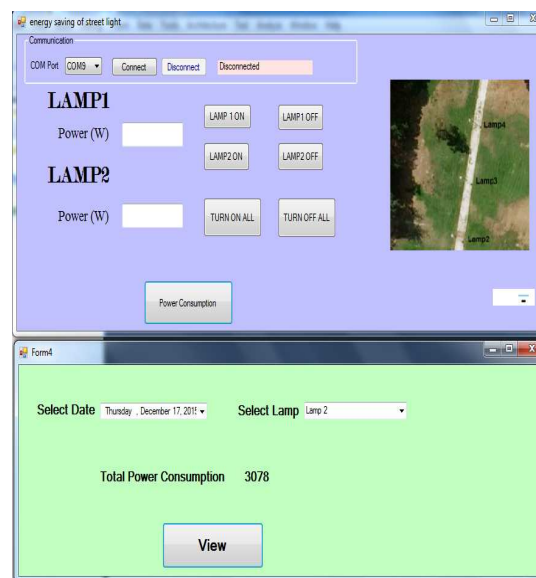

Figure 7: Graphical result windows

Table 1 unit consumption comparison

Baseline Fittings	Units Per Month (12 Hrs)	Units Per Month (Proposed System)
Type		
FTL T12 40W - 1.2m	18	6
FTL T12 40W - 1.2m	18	6
HPSVL 70	29.52	9.84
MVL125	52.2	17.4

MVL125	52.2	17.4
HPSVL/MVL 150	63	21
HPSVL/MVL 150	63	21
HPSVL/MVL 250	102.6	34.2
HPSVL/MVL 250	102.6	34.2
HPSVL/MVL 150	63	21

FTL = Fluorescent Tubular Lamp, HPSVL = High Pressure Sodium Vapor Lamp, MVL = Mercury Vapor Lamp, Low Pressure Mercury Fluorescent Tubular Lamp (T12 &T8), Energy-efficient Fluorescent Tubular Lamp (T5), Light Emitting Diode (LED) [6]

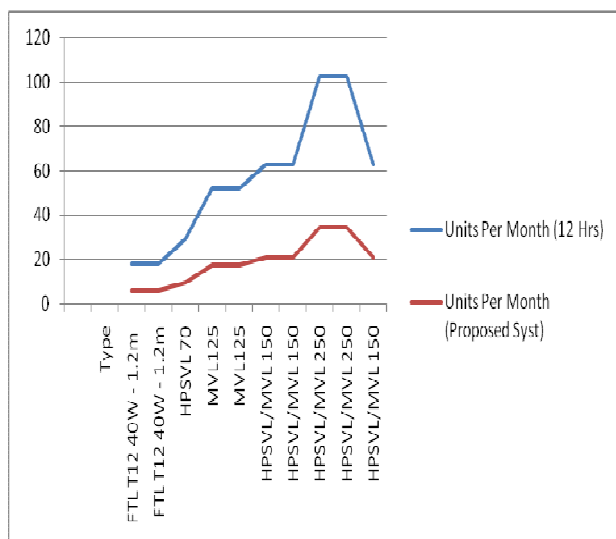

5. CONCLUSION

A new intelligent street lighting system which integrates new technologies available in the market to offer higher efficiency and considerable savings. This can be achieved using the highly efficient LED technology supplied by renewable energy of solar panels, for which the cost of energy is independent from the power supplier prices, combined to an intelligent management of the lamp posts derived by a control system switching on the light only when necessary, increasing the lamps' lifetime. Another advantage obtained by the control system is the intelligent management of the lamp posts by sending data to a central station by ZigBee wireless communication. The system maintenance can be easily and efficiently planned from the central station, allowing additional savings.

The proposed system is particularly suitable for street lighting in urban and rural areas where the traffic is low at a given range of time. The independent nature of the

power-supply network enables implementing the system in remote areas where the classical installations are prohibitively expensive. The system is always flexible, extendable, and fully adaptable to user needs. The simplicity of ZigBee, the reliability of electronic components, the feature of the sensor network, the processing speed, the reduced costs, and the ease of installation are the features that characterize the proposed system, which presents itself as an interesting engineering and commercial solution as the comparison with other technologies demonstrated.

The system can be adopted in the future for loads supplied by the power system, which enables the monitoring of energy consumption. This situation is particularly interesting in the case of economic incentives offered to clients that enable remote control of their loads and can be useful, for example, to prevent the system blackout. Moreover, new perspectives arise in billing and in the intelligent management of remotely controlled loads and for smart grid and smart metering applications.

REFERENCES

- [1] Sakshee Srivastava, Automatic Street Lights: Advance in Electronic and Electric Engineering, 2013.
- [2] Isah Abdulazeez Watson, Oshomah Abdulai Braimah, Alexander Omoregie, Design and Implementation of an Automatic Street Light Control System, International Journal of Emerging Technology and Advanced Engineering, March 2015.
- [3] Sharath Patil G.S, Rudresh S.M, Kallendrachari.K, Design and Implementation of Automatic Street Light Control Using Sensors and Solar Panel, Int. Journal of Engineering Research and Applications, June 2015.
- [4] Satwinder Singh, Suman Bhullar, Automatic Street Lighting System uses NE555 Integrated Circuit and LDR, Journal of The International Association of Advanced Technology and Science, JANUARY 2015.
- [5] P.-Y. Chen, Y.-H. Liu, Y.-T. Yau, and H.-C. Lee, Development of an energy efficient street light driving system, in Proc. IEEE Int. Conf. Sustain. Energy Technol., Nov. 24–27, 2008, pp. 761–764.
- [6] Republic of India Energy-Efficient Urban Street Lighting India: “Energy-Efficient Street Lighting Implementation and Financing Solutions” June 2015.
- [7] Alissa Johnson, Amol Phadke, Stephane de la Rue du Can, ernest orlando lawrence berkeley national laboratory “Energy Savings Potential for Street Lighting in India February 2014”, 2014.
- [8] Budget connect +2015 “ Government of India full budget 2015”, 2015.